



Assembly Guide



IRVIN STEEL
A Division of Inco International Inc.

IMPORTANT!

Read ALL instructions before beginning job. These instructions are provided to avoid problems that may occur from the improper assembly and installation of the StormTamer™. The manufacturer and/or distributor are not responsible for failure resulting from improper assembly or installation of the StormTamer™. Moreover, all warranties are void for failure to follow these assembly instructions.

Prior to installing the StormTamer™ panel-less frame, it is imperative that the structure has an adequate number of stringers. Stringer quantity and spacing for standard size structures can be found at www.isioutdoor.com/panelfreeframes.asp. ALL stringers must be inspected and found to be in good condition prior to frame installation. Poor stringer conditions WILL jeopardize the integrity of the unit and its ability to meet high wind loads and the StormTamer's ability to function as designed.

Inspection

StormTamer™ frame components are visually inspected for physical defects and deficiencies prior to shipment. However, purchasers should inspect all components of the StormTamer™ for visible defects prior to assembly and installation. Do NOT assemble a StormTamer™ frame from components of unacceptable or questionable quality. Irvin International shall not be responsible for assembly, installation or removal costs resulting from the use of unacceptable or questionable quality components.

- BE SURE TO ACCOUNT FOR AND USE ALL SUPPLIED COMPONENTS. (Several extra bolt assemblies are included with each shipment, however ALL various components included in the shipment are necessary and REQUIRED for proper installation.)
- The frame arrives partially assembled. DO NOT REMOVE ANY FEET, ANGLES or BOLTS without contacting Irvin Steel for further instructions.
- DO NOT HAMMER WITH ANYTHING OTHER THAN A RUBBER Mallet.
- DO NOT WELD.
- Skin irritation due to glass fibers may be avoided by applying a barrier cream to exposed skin areas prior to working with fiberglass.

1) Unpack unit(s) from skid(s). A Checklist is included in every unit. Be sure that all member lengths and other products, including hardware, are accounted for. Mating Beams should be stacked on top of one another, ie. Top and Bottom Beams (see Figure 1).

2) Refer to Drawings throughout instructions to Locate Referenced Parts.

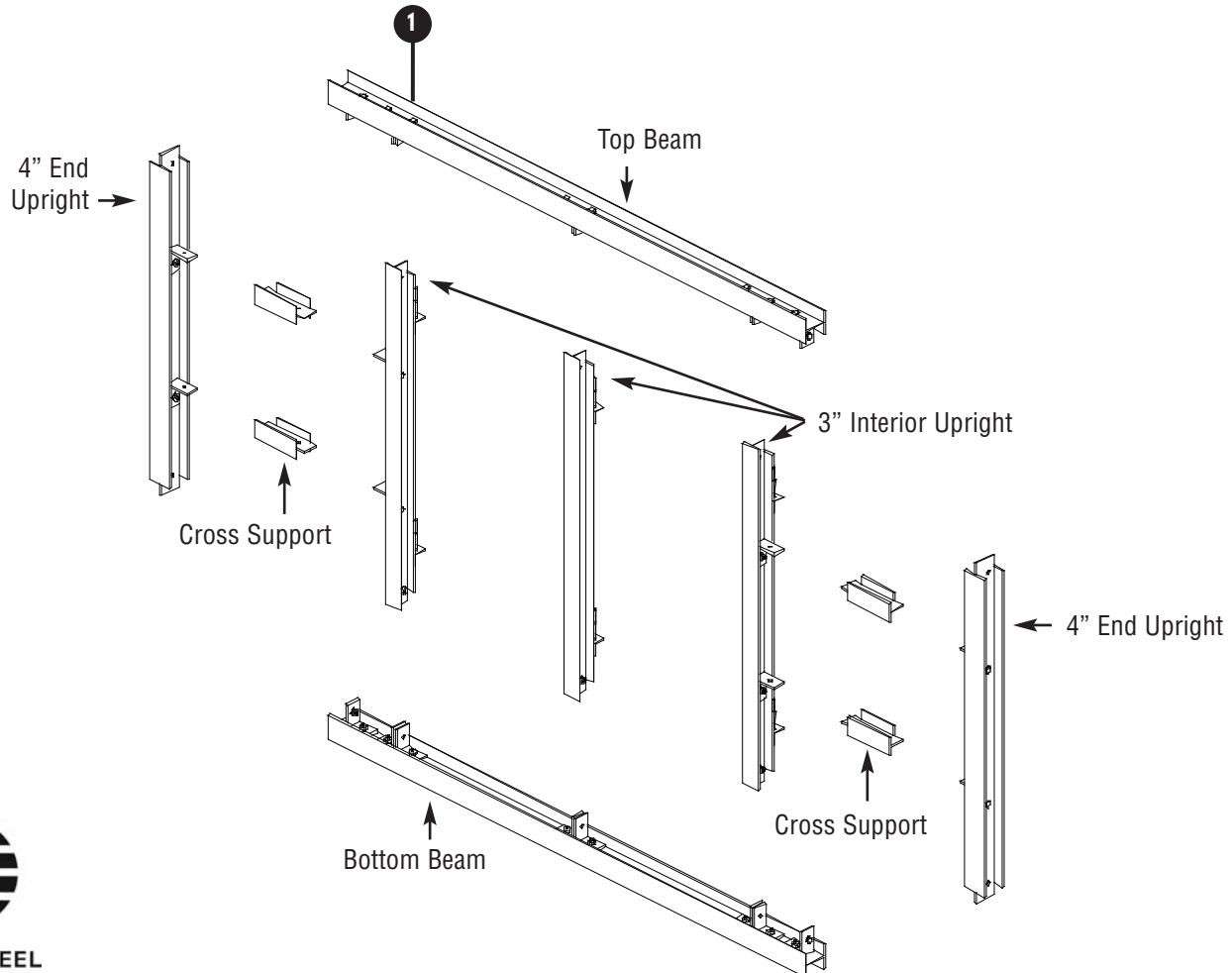

3) Locate Top and Bottom Beams with Fiberglass Angles (“feet”) attached. Any Top/Bottom Beams with “feet” located on the ends (meaning side-by-side) will be on the ends (see Figure 2).

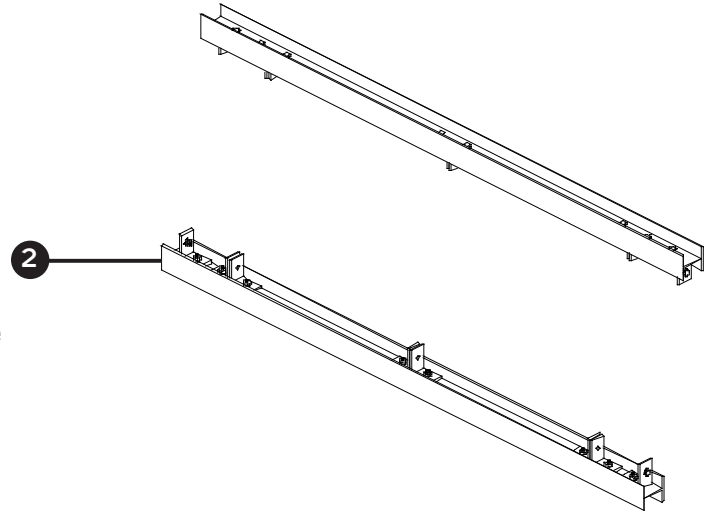

4) If assembling a larger frame (ex. 14ft x 48ft), be sure to line up the beams on the ground. In the example of the 14ft x 48ft, the Top Beams should line across the top with the “feet” facing down in this order (left to right) – (1) 20ft End Top Beam, (1) 8ft Top Beam, (1) 20ft End Top Beam. The corresponding Bottom Beams should be laid out below those in the same order with “feet” facing upward.

5) For larger units where beams will be spliced together, splice plates are included and finger tightened onto select beams. Loosen and remove the bolt assembly securing the splice plates. Place one of the two splice plates on the underside of the beam (flat part up, see Figure 3). Additional bolt assemblies are included with the shipment. Use the original bolt assembly as well as one additional assembly to attach two Top/Bottom beams, as show in figure 3a. Be sure to use two splice plates per connection — one on top, one underneath (see Figure 3a).

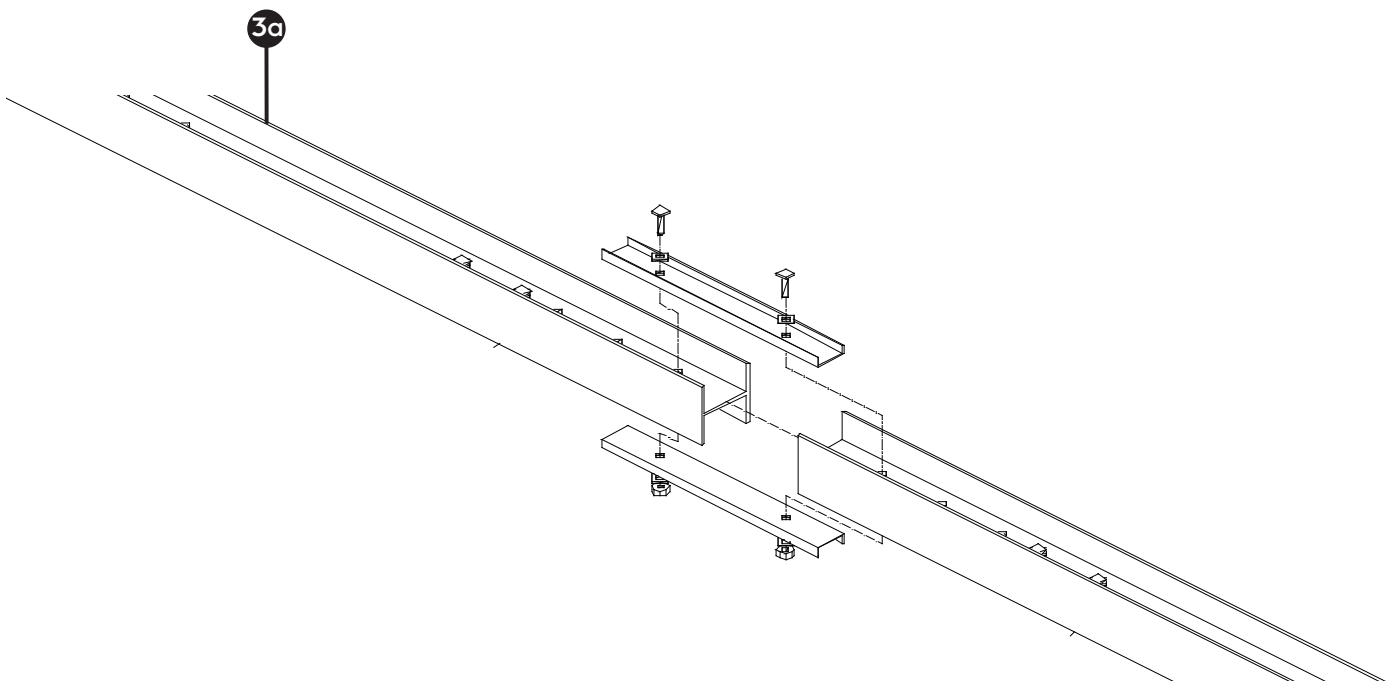
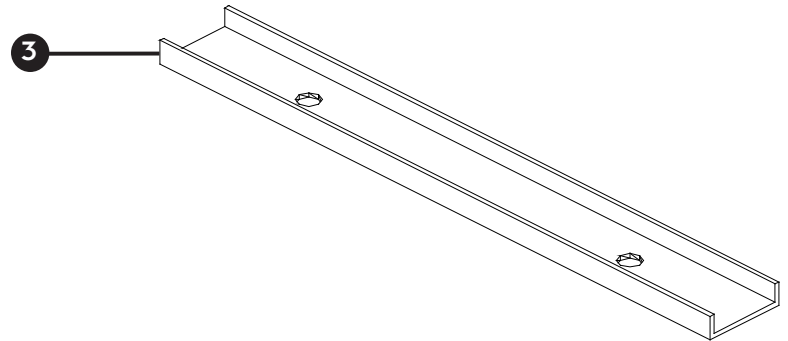

- 6) Locate Coped "Upright" Beams. These will be the 2pcs of 4" Wide Beams and all 3" Wide Beams included with the shipment. The 4" Beams are coped on both sides. The 3" Beams are coped on one side only (see Figure 4).

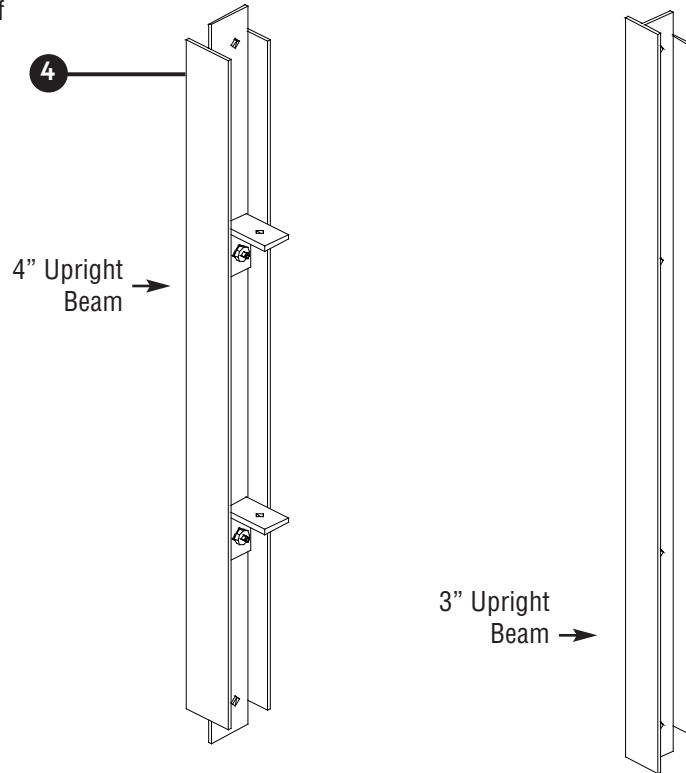

- 7) Utilize 4 Cross Braces provided with shipment. Secure two Cross Braces as shown for both ends of the frame unit. You will Utilize (1) 4" Upright and (1) 3" Upright per set. Be sure that the coped end of the 3" beam is facing toward the back as shown. The coped end faces the backside of the frame (see Figure 5).

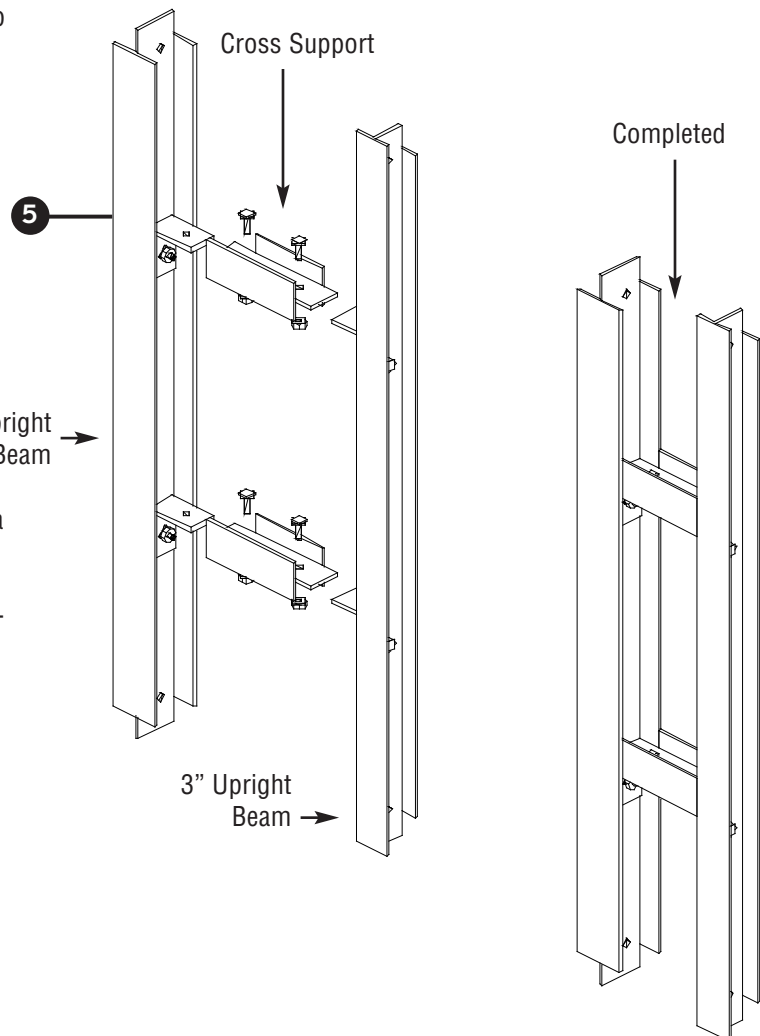

- 8) Now lay all remaining 3" Beams and the 2 Sets created in Step 7 on the ground. They should all be laying with the coped sides of 3" Beams all facing up, as you will be preparing to drill into the backside of the beams.

- 9) Measure for stringer spacing. Each frame includes either a Steel Stringer Kit or a Wood Stringer Kit. It is very important that all materials included in each kit is utilized. Failure to use all components (excluding extra bolt assemblies) in the manner instructed and/or required will jeopardize the integrity of the unit.



10) Transfer stringer measurements onto 3" coped uprights only, including those attached to the 4" Uprights with Cross Braces. However, DO NOT put stringer clips on the 4" End Beams.

11) Using a Stringer Clip as a guide (Wood Stringer Clip or Steel Stringer Clip), establish the positioning of the clip and mark with a black marker the hole locations. REMEMBER: The lip of the clip must be at the top of the stringer. Do this for ALL 3" Upright Beams (see Figure 6).

12) Drill each marked hole with 7/16" drill bit. This may seem tedious but it goes quickly with fiberglass.

13) Select one of the following two options: Place all the Upright Beams on the Stringers individually and then attach the Top and Bottom Beams OR Assembly the entire frame on the ground and fly it to the board
IMPORTANT: Do NOT tighten any bolts before aligning the frame on the board. "Finger Tight" is all that is needed to get the components seated on the board. Once the frame is centered and squared, THEN begin to fully tighten all beams.

14) When placing Upright Beams onto the Stringers, all bolt assemblies MUST be used in the correct fashion. All washers and nuts MUST be used correctly. LAG BOLT ASSEMBLIES MUST BE USED FOR ATTACHING WOOD STRINGER CLIPS TO WOOD STRINGERS (see Figure 7).

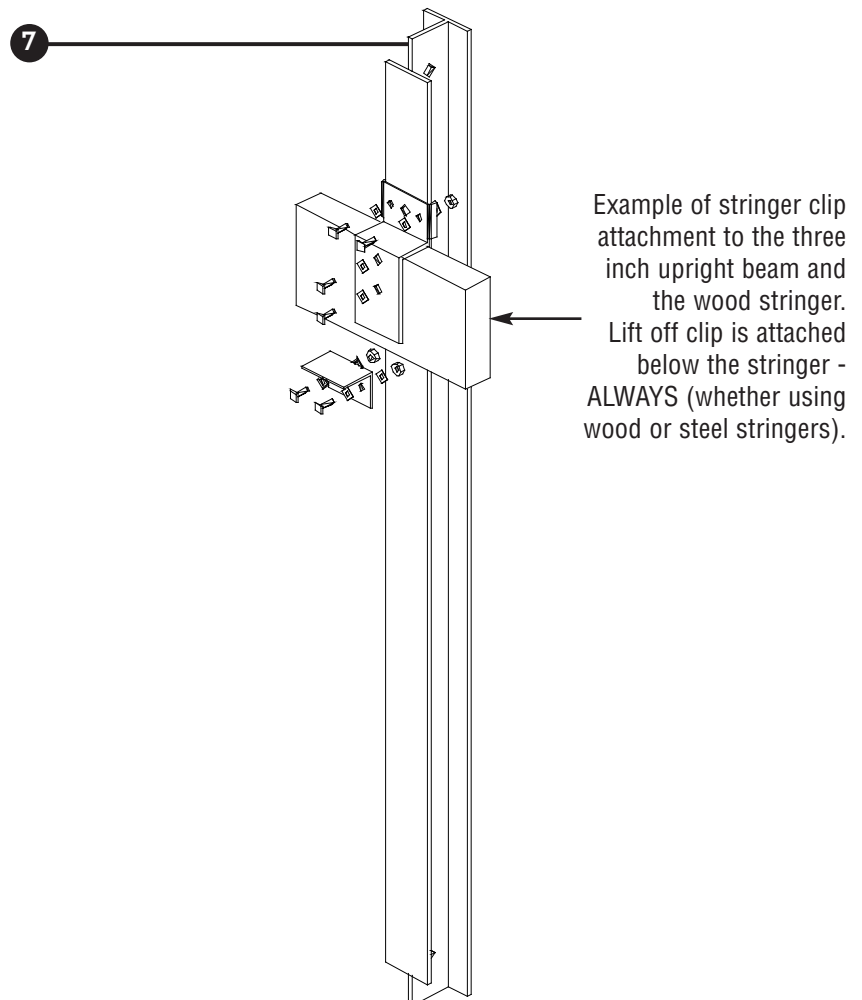
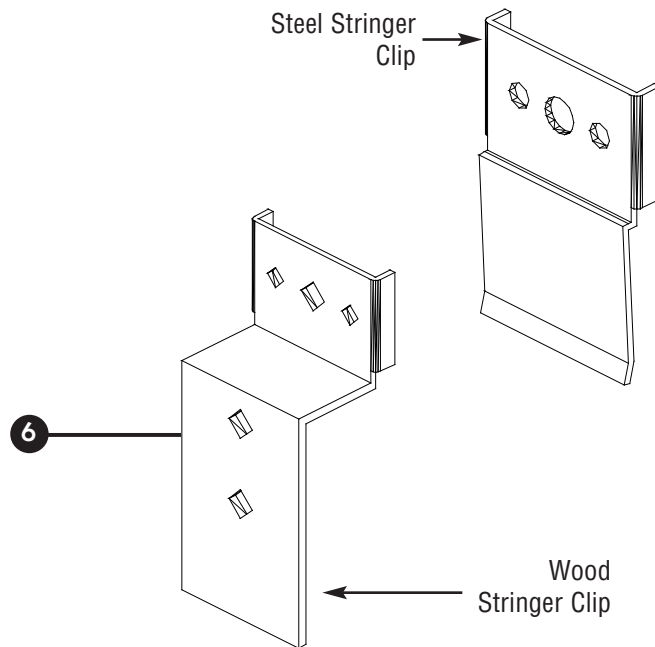

15) If building piece-by-piece onto the structure, once the Top and Bottom Beams are fully assembled, locate the End Upright Sets. Attach as shown on each end, but be sure to attach only to the Top Beams (see Figure 8).

16) Begin to Assemble the remaining 3" Coped Beams to the Top Beams. Again, be sure the coped side is facing to the back. Remember to leave the bolts finger tight only.

17) Once the beams are in place, repeat the procedure with the Bottom Beams.

18) If lifting into place with a crane, please use 3 slings
MINIMUM – 4 is PREFERRED. Be sure to attach a sling in the middle of the frame and not just the ends.

19) THERE WILL BE FLEX IN THE FRAME. THIS IS NORMAL AND SHOULD NOT CAUSE ALARM. MOVE SLOWLY. THE FRAME WILL "STIFFEN" ONCE SEATED ON THE FACE.

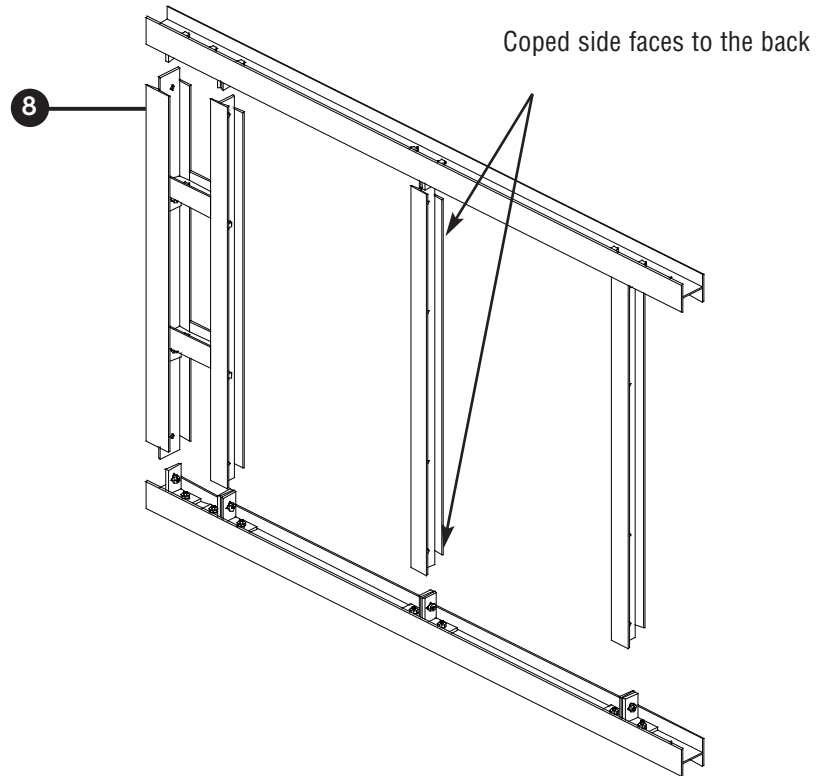

20) Guide frame onto stringers. Once frame is seated, be sure to square and level as best as possible.

21) Now, tighten all bolts. DO NOT OVER TORQUE.

22) Begin to locate Lift Off Brackets and mark hole locations with marker. REMEMBER: Lift Off Brackets are placed on top and bottom structure stringers. For structures with four or more stringers, Lift Off Clips should be used on top and bottom stringers, as well as on one of every two remaining stringers. Lift Off Clips must be used on every 3" upright beam. (see Figure 9).

Lift off Bracket

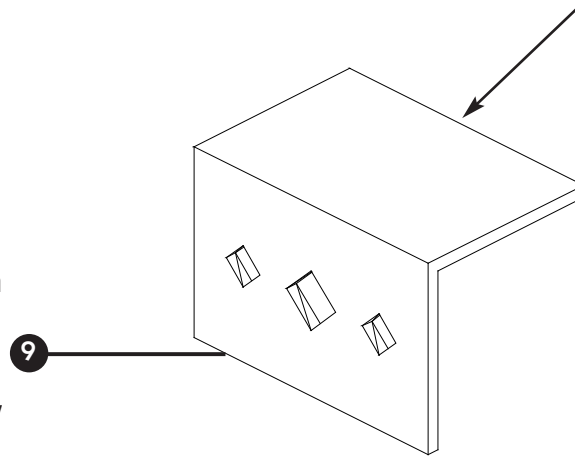

23) Drill holes with 7/16" drill bits and assemble as shown below (see Figure 10).

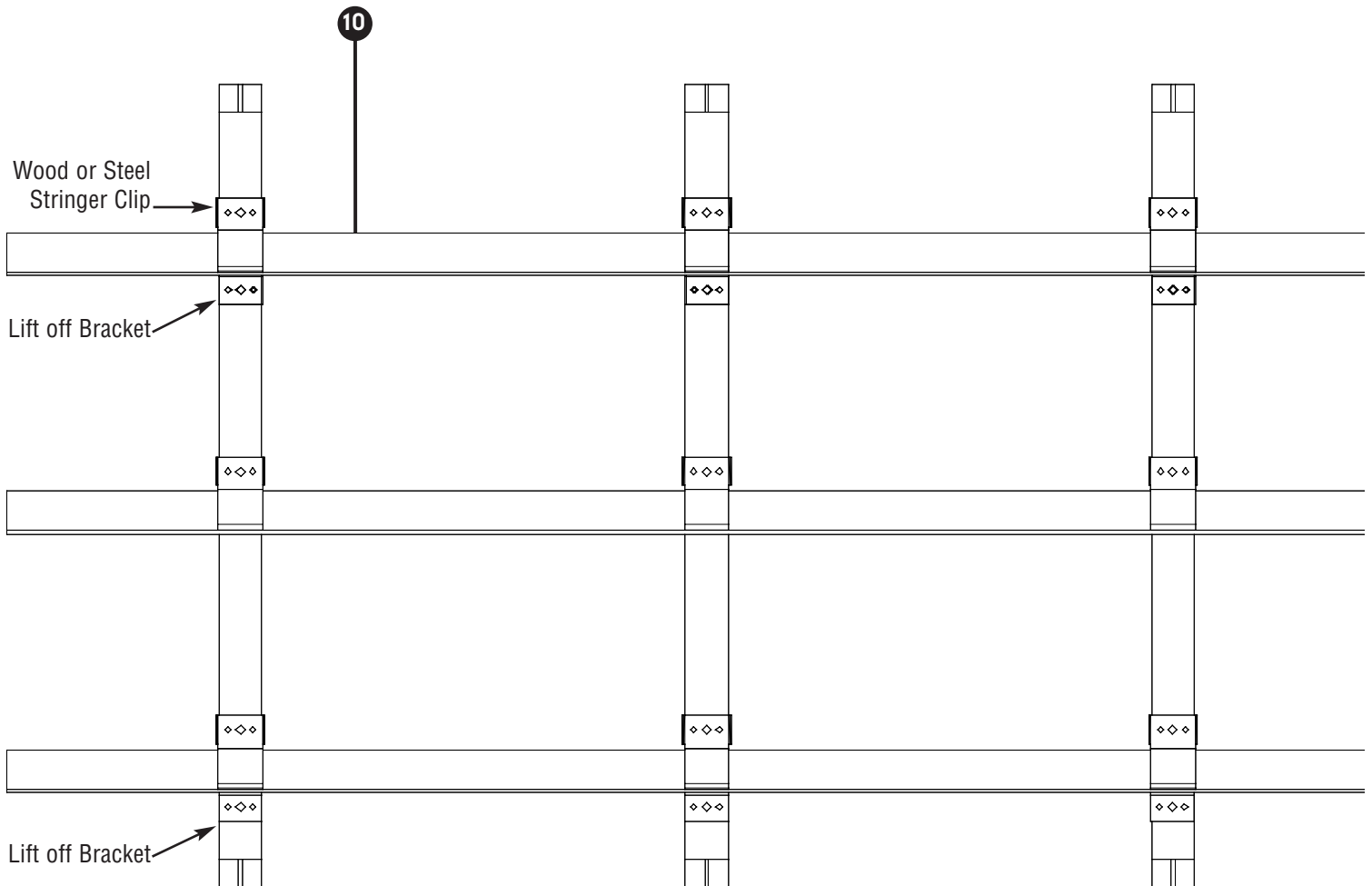

24) Unit is complete (see Figure 11).

CRITICAL: ALL BOLT ASSEMBLIES MUST BE INSTALLED CORRECTLY IN RELATION TO VARIOUS FITTINGS. FAILURE TO COMPLY WITH THESE INSTRUCTIONS JEOPARDIZES THE INTEGRITY OF THE UNIT AND IT'S ABILITY TO MEET HIGH WIND LOADS.

For installation of Insert Vinyl, J bolts are included. Install J bolts into remaining pre-drilled holes on perimeter beams. Insert 5/8" gripper rods into the inset vinyl. Slit vinyl so that gripper rod can be hooked into J bolts. Tension J Bolts.

Installation of Vinyl Clips — are not recommended on StormTamer™ panel-less frames.

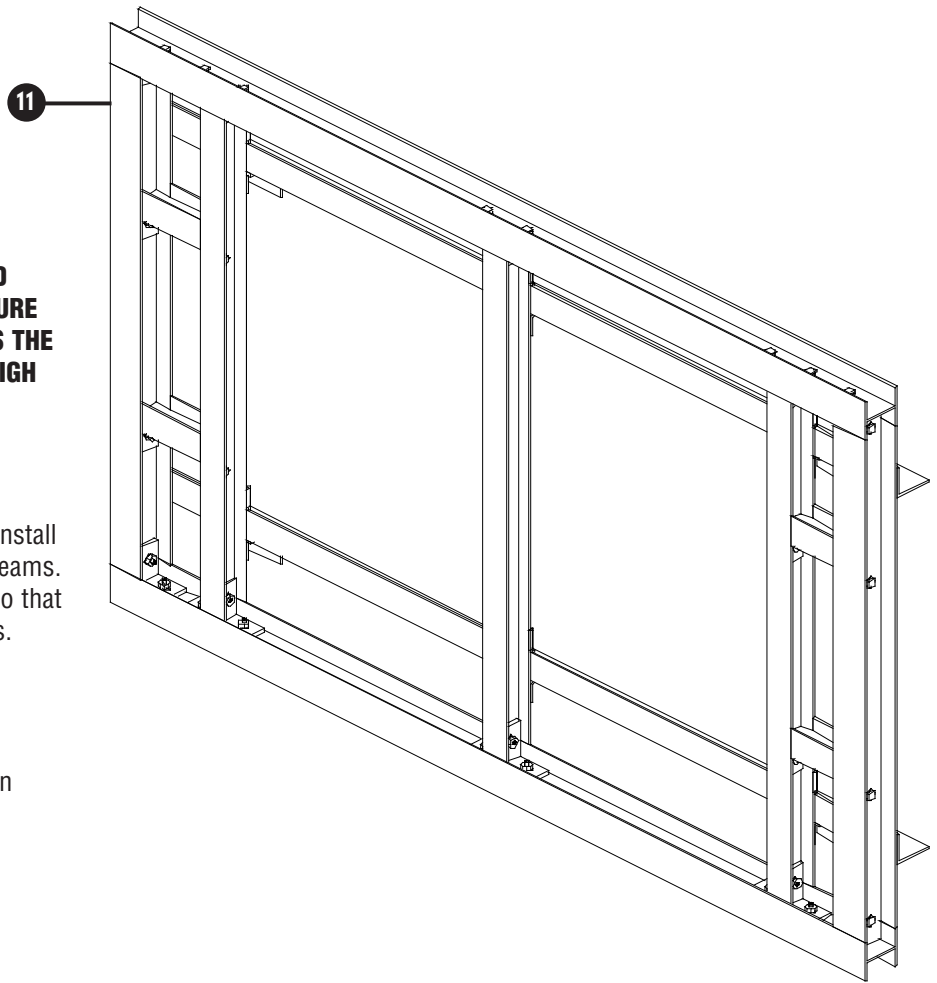

Product Warranty. THE COMPANY warrants that PURCHASER shall acquire PRODUCTS purchased hereunder free and clear of all liens and encumbrances. THIS CONSTITUTES THE SOLE WARRANTY MADE BY THE COMPANY EITHER EXPRESSED OR IMPLIED. THERE ARE NO OTHER WARRANTIES EXPRESSED OR IMPLIED WHICH EXTEND BEYOND THE FACE HEREOF, HEREIN, INCLUDING THE IMPLIED WARRANTIES OR MERCHANTABILITY AND FITNESS FOR A PARTICULAR PURPOSE. IN NO EVENT SHALL THE COMPANY BE LIABLE FOR ANY INCIDENTAL OR CONSEQUENTIAL DAMAGES AND DISTRIBUTOR'S REMEDIES SHALL BE LIMITED TO REPLACEMENT OF NONCONFORMING PRODUCTS.

Limited Liability. NOTWITHSTANDING ANYTHING ELSE IN THIS AGREEMENT OR OTHERWISE, THE COMPANY WILL NOT BE LIABLE WITH RESPECT TO ANY SUBJECT MATTER OF THIS AGREEMENT UNDER ANY CONTRACT, NEGLIGENCE, STRICT LIABILITY OR OTHER LEGAL OR EQUITABLE THEORY FOR (1) ANY AMOUNTS IN EXCESS IN THE AGGREGATE OF THE AMOUNTS PAID TO THE COMPANY HEREUNDER DURING THE TWELVE MONTH PERIOD PRIOR TO DATE THE CAUSE OF ACTION AROSE OR (2) ANY INCIDENTAL OR CONSEQUENTIAL DAMAGES, LOST PROFITS OF LOST DATA OR (3) COST OF PROCUREMENT OF SUBSTITUTE GOODS, OR SERVICES. THE COMPANY SHALL HAVE NO LIABILITY FOR ANY FAILURE OF DELAY DUE TO MATTERS BEYOND ITS REASONABLE CONTROL.

Assembly Instructions. Failure to follow the current assembly instructions for StormTamer™ voids all warranties express or implied.



Irvin Steel Inc.
8105 Krauss Blvd.
Suite 102
Tampa, FL 33619

Ph: 1-800-474-7846
Local: (813) 664-8945
Fax: (813) 621-6897
Email: information@irvinsteel.com
Web: www.isioutdoor.com