

Ledger Arm Assembly Guide



PLEASE READ ALL INSTRUCTIONS BEFORE BEGINNING INSTALLATION.

These guides are provided in good faith to help prevent assembly problems caused by common errors. The manufacturer and/or distributor of the product bear no responsibility for the assembly actions taken or not taken. These assembly guidelines are strictly recommendations and are not intended to serve as a step-by-step, foolproof checklist.



WHEN CUTTING OR DRILLING FIBERGLASS PRODUCTS, ALWAYS WEAR PROTECTIVE GLASSES OR GOGGLES AND A MASK THAT COVERS THE FACE AND MOUTH. Skin irritation due to glass fibers may be avoided by applying a barrier cream to exposed skin areas prior to working with fiberglass.

INSPECTION

Every attempt is made to inspect product for any physical abnormalities prior to shipment, however all product should be inspected for any defects prior to assembly. Do not assemble product of unacceptable or questionable quality. Irvin Steel will not be responsible for assembly or removal costs of unacceptable parts.

- 1) Example of completed ledger arm setup for both faces of poles being utilized with catwalks laid on top of ledger arms to demonstrate correct use.

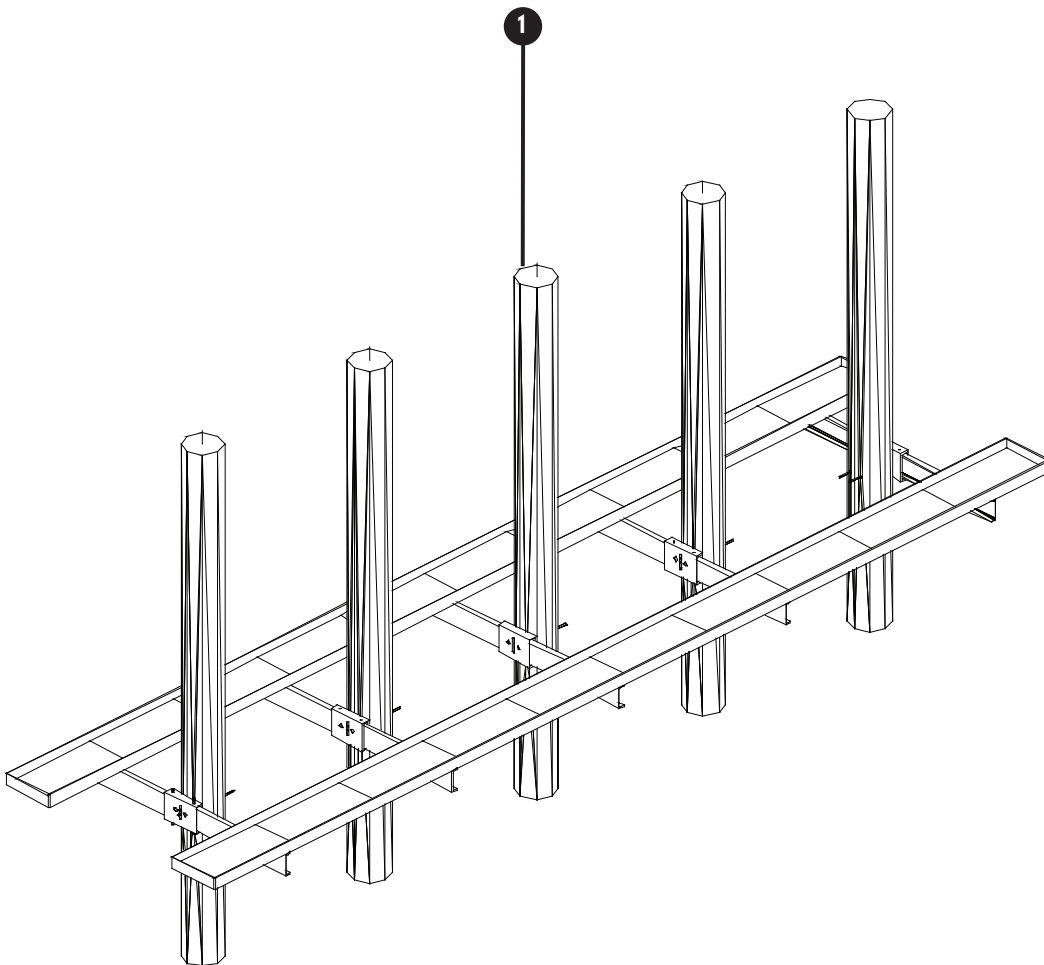

2) Locate hole and mount location.

3) Drill 1/4" thru holes into poles.

4) Place 1" bolts into face of mounts, than through the pole and level/square mount and tighten bolts – be sure to use plate on back side to bore against.

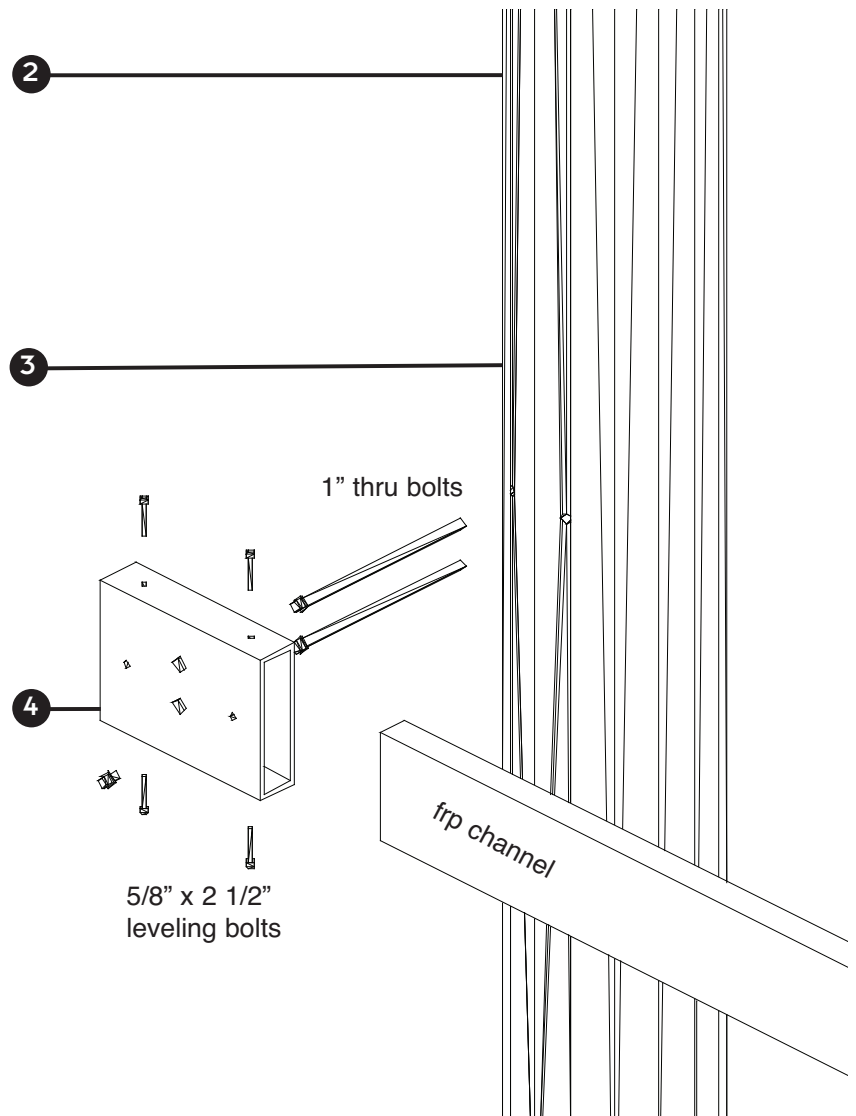

5) Insert channel into arm – be sure flat of channel is flush against face of mount and begin to tighten leveling bolts to make channel is snug.

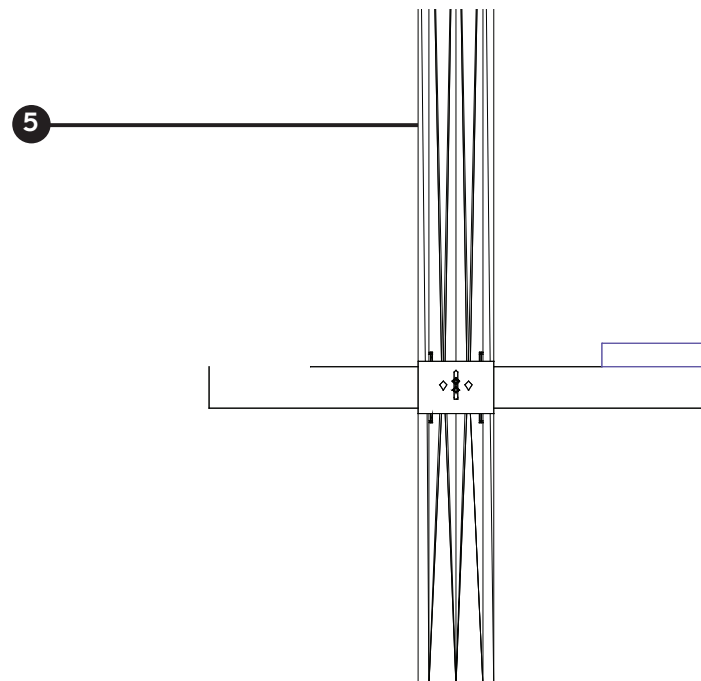

6) Be sure you are still utilizing a string line for location and use leveling bolts to bring arm (channel) into level; continue with each arm.

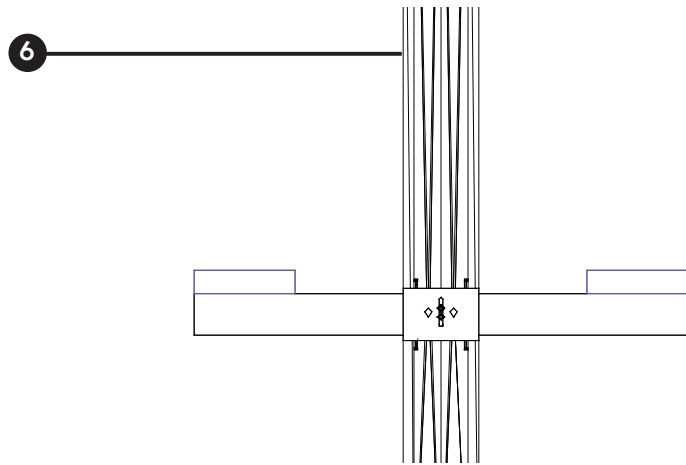

7) Once all arms are level, drill 2 5/8" holes through channel using hole on face of mount as guide.

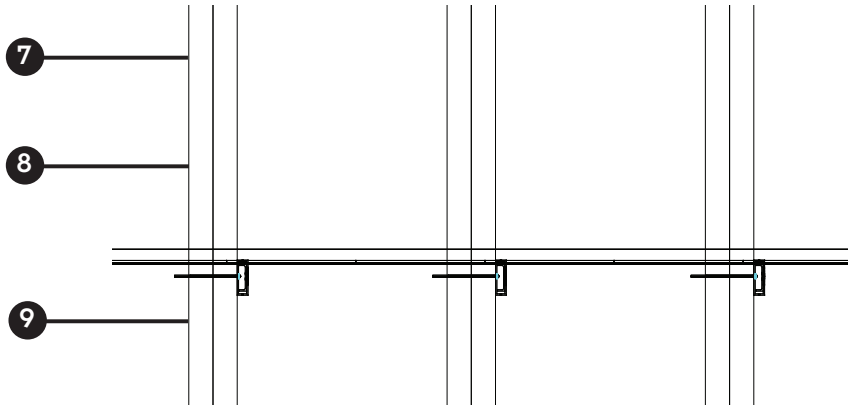

8) Insert 5/8" bolt from inside out and tighten down – be sure to use complete bolt assembly.

9) Tighten nuts on leveling arms

10) Completed assembly

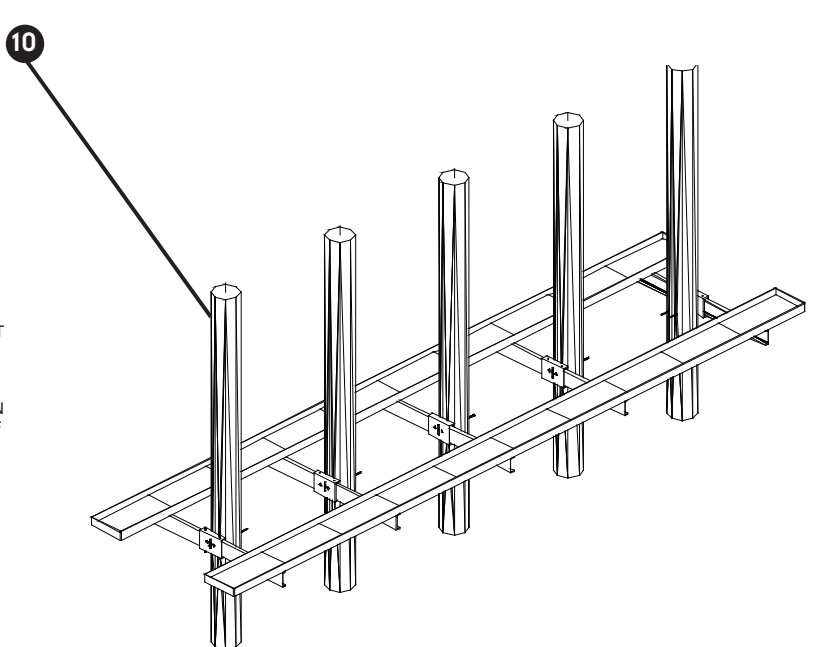

Product Warranty. THE COMPANY warrants that PURCHASER shall acquire PRODUCTS purchased hereunder free and clear of all liens and encumbrances. THIS CONSTITUTES THE SOLE WARRANTY MADE BY THE COMPANY EITHER EXPRESSED OR IMPLIED. THERE ARE NO OTHER WARRANTIES EXPRESSED OR IMPLIED WHICH EXTEND BEYOND THE FACE HEREOF, HEREIN, INCLUDING THE IMPLIED WARRANTIES OR MERCHANTABILITY AND FITNESS FOR A PARTICULAR PURPOSE. IN NO EVENT SHALL THE COMPANY BE LIABLE FOR ANY INCIDENTAL OR CONSEQUENTIAL DAMAGES AND DISTRIBUTOR'S REMEDIES SHALL BE LIMITED TO REPLACEMENT OF NONCOMFORMING PRODUCTS.

Limited Liability. NOTWITHSTANDING ANYTHING ELSE IN THIS AGREEMENT OR OTHERWISE, THE COMPANY WILL NOT BE LIABLE WITH RESPECT TO ANY SUBJECT MATTER OF THIS AGREEMENT UNDER ANY CONTRACT, NEGLIGENCE, STRICT LIABILITY OR OTHER LEGAL OR EQUITABLE THEORY FOR (1) ANY AMOUNTS IN EXCESS IN THE AGGREGATE OF THE AMOUNTS PAID TO THE COMPANY HEREUNDER DURING THE TWELVE MONTH PERIOD PRIOR TO DATE THE CAUSE OF ACTION AROSE OR (2) ANY INCIDENTAL OR CONSEQUENTIAL DAMAGES, LOST PROFITS OF LOST DATA OR (3) COST OF PROCUREMENT OF SUBSTITUTE GOODS, OR SERVICES. THE COMPANY SHALL HAVE NO LIABILITY FOR ANY FAILURE OF DELAY DUE TO MATTERS BEYOND ITS REASONABLE CONTROL.

Assembly Instructions. Failure to follow the current assembly instructions for Ledger Arm voids all warranties express or implied.



Irvin Steel Inc.
8105 Krauss Blvd.
Suite 102
Tampa, FL 33619

Ph: 1-800-474-7846
Local: (813) 664-8945
Fax: (813) 621-6897
Email: information@irvinsteel.com
Web: www.isioutdoor.com